

14-500

433-MHZ KEYPAD AND TRANSCEIVER

FEATURES

- 500 four-digit access-code capacity
- Latch mode
- Wireless range up to 500 feet
- Control up to 2 devices from 1 keypad*
- Pair up to 40 keypads and/or remotes
- Personal master code
- Limited-use code (1 to 9 uses)
- "3 strikes, you're out" security
- Variable relay time
- Audible-tone feedback
- Backlit keypad
- Polycarbonate construction



* Requires two Ridge Transceiver units

GOES WHERE YOU GO

No wires mean freedom—this system can be located and mounted anywhere you need it.

FITS YOUR NEEDS

Whether it's a simple installation or a multiple-keypad/multiple-remote setup, your configuration options are limitless.

SOLAR FRIENDLY

An ultra-low current draw means it plays well with your solar gate operator.

GO WIRELESS

Ridge Wireless™ technology allows two-way wireless connection, making your system more versatile and more responsive.

SPECIFICATIONS (KEYPAD)

ELECTRICAL

Input 9 VDC *

ENVIRONMENTAL

Operating Temperature -15 to 175 °F

* Includes 9-V alkaline battery.

SPECIFICATIONS (TRANSCEIVER)

ELECTRICAL

Input 12-24 VAC/DC

Current Draw less than 7.9 mA @ 12 VDC
standby

less than 11.2 mA @ 12 VDC
with relay latched

RELAY

Contact Rating 2 A @ 30 V / .5 A @ 120 V
DC Load / AC Load

Max Carrying Current 2 A / 2 A

Variable Relay Time 1-999 seconds

COMMUNICATION

Radio Frequency 433 MHz

ENVIRONMENTAL

Operating Temperature -15 to 175 °F

MOUNTING (KEYPAD)

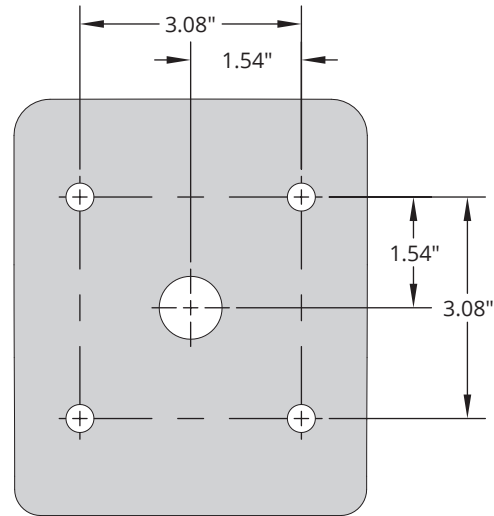

HOLE SIZES

Wiring pass through 0.88"

Mounting holes (x4) 0.38"

Unit includes mounting hardware.

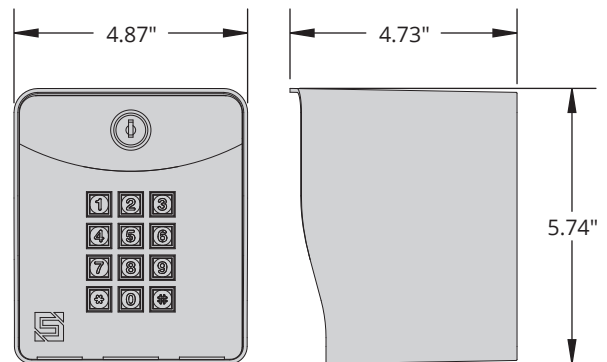

14-500T keypad shown

AVAILABLE MODELS (SEE PRICE GUIDE TO SEE ALL MODELS, INCLUDING REMOTE & KEYPAD HD)

MODEL	DESCRIPTION	DIMENSIONS	SHIP. WEIGHT
14-500	keypad and transceiver	see component dimensions	3 lbs.
14-500T	keypad	5.74"(H) x 4.87"(W) x 4.73"(D)	3 lbs.
14-REC20	transceiver	5.25"(H) x 2.75"(W) x 1.13"(D)	1 lb.