

# ADVANTAGE DKLP



19-100 SERIES

100-CODE LOW-POWER KEYPADS

## FEATURES

- Low current draw
- Control 1 gate/door
- 100 four-digit code capacity
- Personal master code
- Latch code
- Variable relay time
- Alarm shunt
- Audible-tone feedback
- Non-volatile memory



ADVANTAGE

SOLID ACCESS CONTROL FOR OVER 35 YEARS

## NO-NONSENSE OPERATION

If you're looking for keypads that are easy to program and easy to use, look no further!

## GOES WHERE YOU GO

With such a low current draw, these units can be located in the remotest of locations, as long as sunlight is sufficient.

## STURDY AND DURABLE

All our products are made from high-quality materials that will last for years to come.

## PROGRAMMING YOU KNOW

Quick, simple, and familiar, the basic programming steps on the keypad are identical to those on all our keypads.



## SPECIFICATIONS

### PHYSICAL

#### 19-100

Dimensions 5.22"(H) x 5.22"(W) x 5.10"(D)

Shipping Weight 4 lbs.

#### 19-100I

Dimensions 5.80"(H) x 7.45"(W) x 5.25"(D)

Shipping Weight 6 lbs.

#### 19-100SG

Dimensions 4.50"(H) x 2.75"(W) x 0.75"(D)

Shipping Weight 1 lb.

### ELECTRICAL

Input 12 VDC  
power supply not included

Current Draw less than 6.0 mA @ 12 VDC  
with relay latched

### RELAY

Contact Rating 2 A @ 30 V / .5 A @ 120 V  
DC Load / AC Load

Variable Relay Time 1-9 seconds

### ENVIRONMENTAL

Operating Temperature -15 to 175 °F

## MOUNTING (19-100)

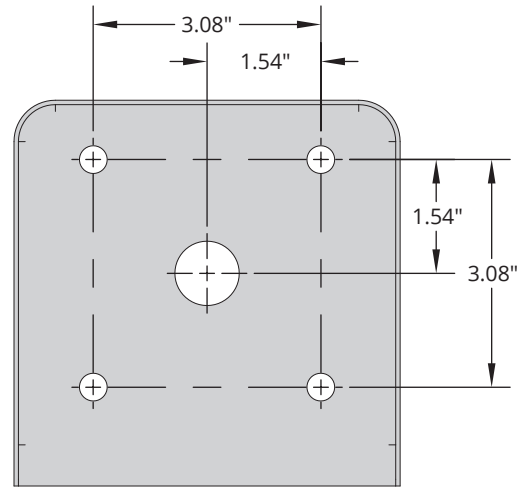

### HOLE SIZES

Wiring pass through **0.88"**  
Mounting holes (x4) **0.38"**

*Unit includes mounting hardware.*

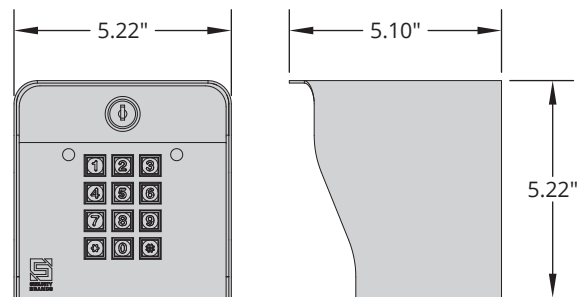

19-100 shown

## AVAILABLE MODELS



19-100  
Post Mount



19-100I  
Post Mount w/ Intercom



19-100SG  
Single Gang



19-100E  
Post Mount Economy