



1 Carefully unpack box.

2 Make sure you have all items shown here. (Screwdriver not shown)

RTE Unit (includes battery)	Key Switch Keys (may look different)	Lock Key	Carriage Bolt (4x)	Hex Nut (4x)	Hole Plug

What's what?

Important components labeled

You **MUST** have the **Ridge Transceiver (14-REC20)** for the RTE Unit to work. It is bundled with the Ridge 2.0 (14-500), Ridge RTE (14-RTE433), and can be purchased separately as well.

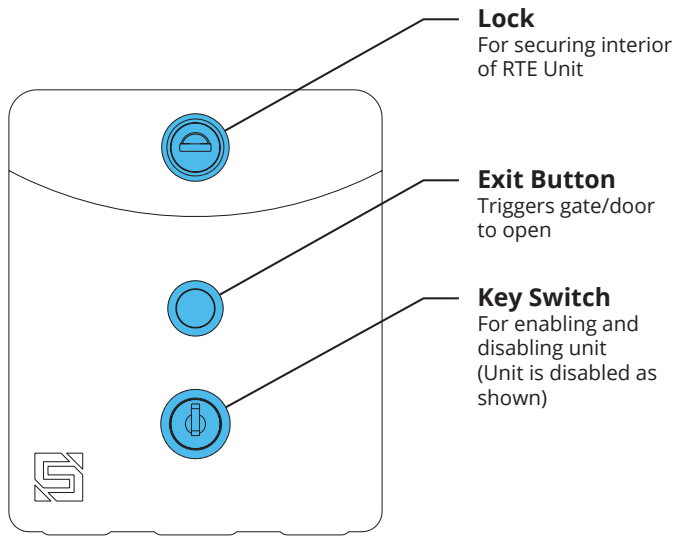

RTE Unit Front Panel (Front)

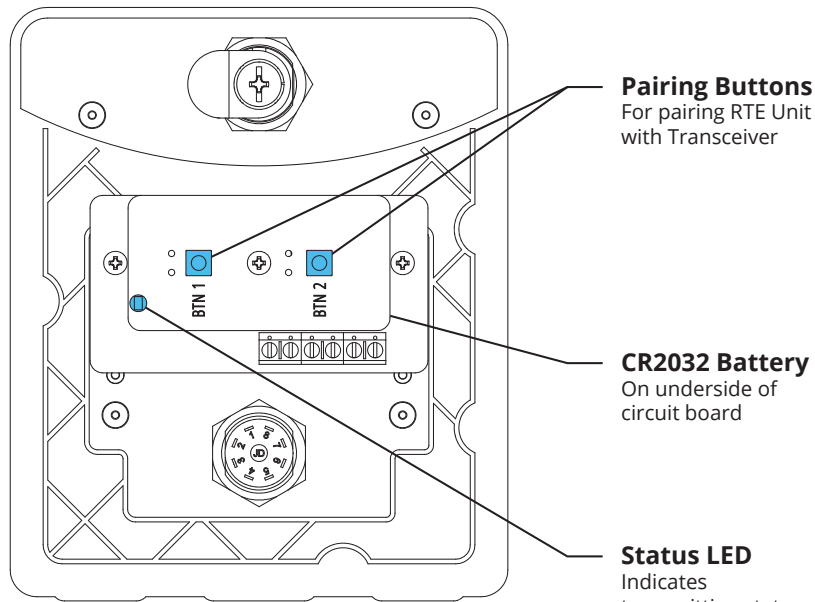

RTE Unit Front Panel (Back)

Internal wiring not shown for clarity.

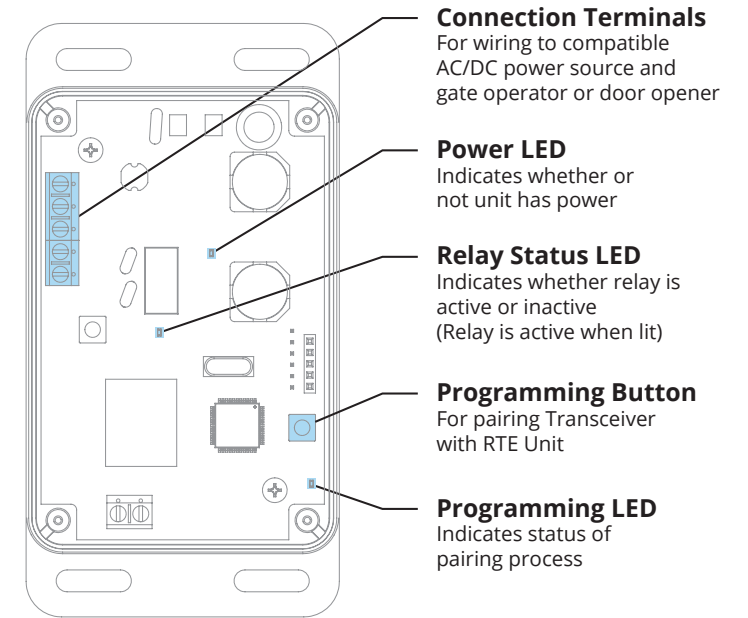

Transceiver (Not Included)

Shown with cover removed.
Internal wiring not shown for clarity.

3 Unlock and remove Front Panel of RTE Unit; then using included Carriage Bolts and Hex Nuts, attach unit to pedestal as shown.

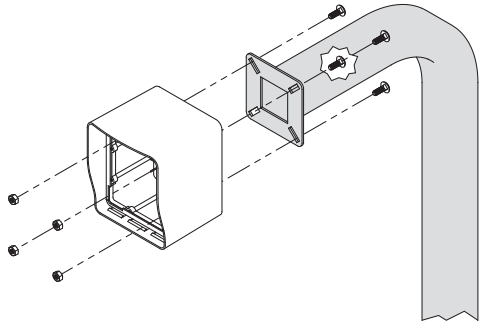

4 Using Tek screws, zip ties, or other means of securing, attach Transceiver to inside wall or another surface inside gate operator.

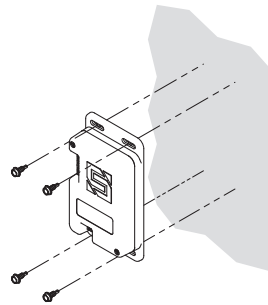

CAUTION!
The Transceiver is not weatherproof and must be mounted inside a weatherproof enclosure. Internal components can be damaged if exposed to the elements.
Failure to comply will VOID WARRANTY.

WARNING!
AUTOMATIC GATES CAN CAUSE SERIOUS INJURY OR DEATH!
ALWAYS CHECK that the **GATE PATH IS CLEAR BEFORE OPERATING!**
REVERSING or other **SAFETY DEVICES SHOULD ALWAYS BE USED!**

5a Connect Transceiver

Gate Operator Timer-to-Close **OFF**

Ridge Transceiver Gate Operator / Door Opener

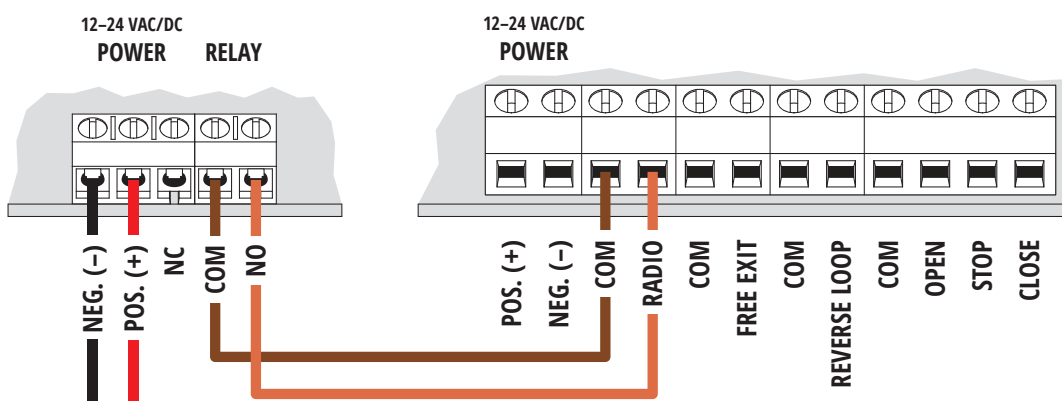

12-24-VAC/DC Power Source (Not Included)

Consult gate operator or door opener manual for exact connections.
Terminals vary widely across manufacturers and models.

5b Connect Transceiver

Gate Operator Timer-to-Close **ON**

Ridge Transceiver Gate Operator / Door Opener

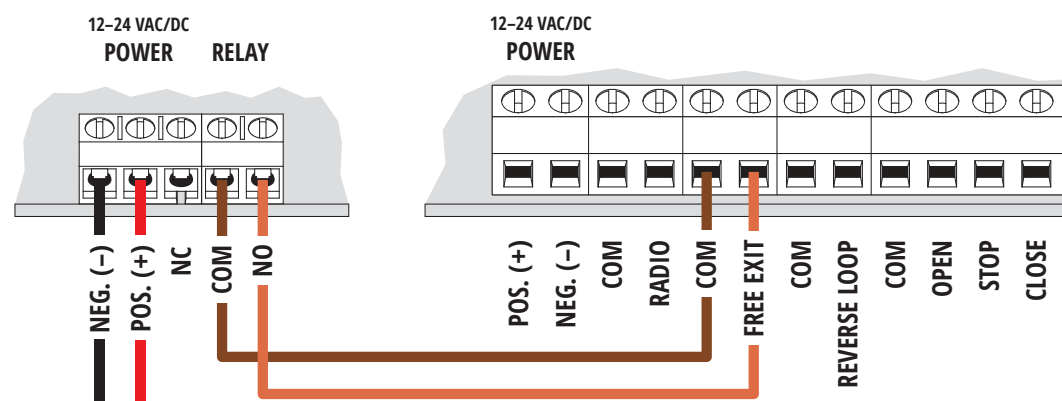

12-24-VAC/DC Power Source (Not Included)

Consult gate operator or door opener manual for exact connections.
Terminals vary widely across manufacturers and models.

CAUTION!
A closing gate can cause injury to persons or damage to property.
ALWAYS USE SAFETY DEVICES!

OR

6a Remove Transceiver cover; then hold down Programming Button on circuit board for 3 seconds and let go.

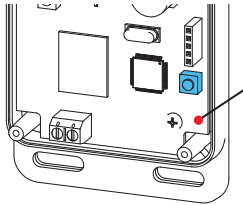

LED will light solid red

6b Remove RTE Unit Front Panel.

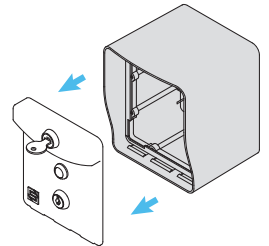

6c Hold down both Pairing Buttons until Status LED flashes. Let go of Button 2, and continue holding Button 1 only until Status LED flashes again.

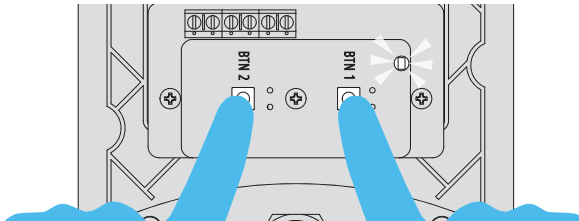

6d Relay on Transceiver should click and Programming LED should go out. Pairing is now complete.

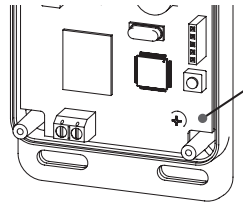

LED will go out

7 Press Exit Button on RTE Unit and confirm gate/door opens.
(If nothing happens, repeat Step 6. If gate/door is held open, see Troubleshooting section on Page 4.)

INSTALLATION COMPLETE!

Your system is ready to use.

! CHECK THAT THE GATE PATH IS CLEAR BEFORE COMPLETING THIS STEP AS IT TRIGGERS THE RELAY!

! CHECK THAT THE GATE PATH IS CLEAR BEFORE COMPLETING THIS STEP AS IT TRIGGERS THE RELAY!

A The RTE Unit can be disabled and re-enabled at any time by taking the Key Switch Keys and using the Key Switch located below the Exit Button.

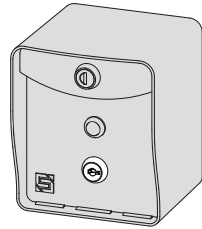

Unit Enabled
(Exit Button active)

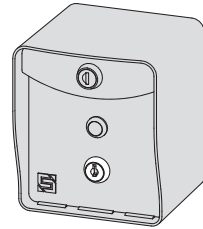

Unit Disabled
(Exit Button inactive)

B Transceiver Reset Procedure

This procedure is used to unpair all devices from the Transceiver.

- Step 1 - Remove screws and remove Transceiver cover.**
- Step 2 - Press and hold Programming Button until Programming LED starts to flash.** Button must be held for about 30 seconds. Once flashing stops, all devices have been unpaired from Transceiver and reset is complete.
- Step 3 - Replace Transceiver cover and secure screws.**

Troubleshooting

RTE Unit is holding gate/door open

IMPORTANT: GATE/DOOR MUST BE CLOSED BEFORE COMPLETING THIS PROCEDURE!

Step 1 - Press Exit Button on RTE Unit to close gate/door if it is not already closed.

Step 2 - Hold down both Pairing Buttons and pay attention to Status LED.

Step 3 - When Status LED flashes twice, continue holding BOTH buttons.

Step 4 - When LED flashes twice again, continue holding Button 1 ONLY until Status LED flashes multiple times.

Now the RTE unit should only hold the gate/door open momentarily.

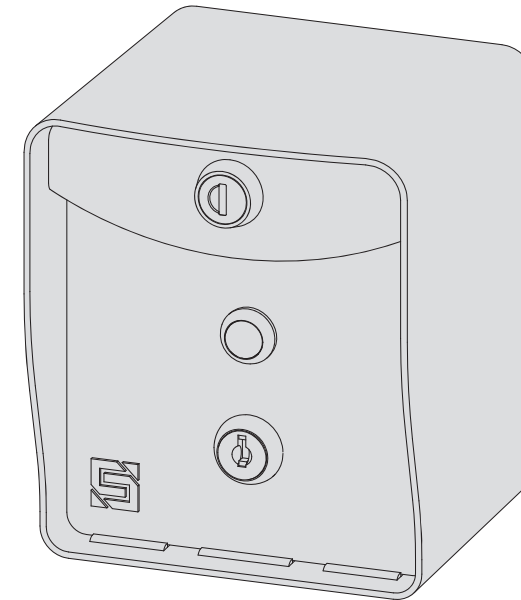

Ridge RTE
14-RTE433T