



**1** Carefully unpack box.

**2** Make sure you have all items shown here. (Screwdriver not shown)

Keypad Unit      Transceiver      9-V Battery      Key      Carriage Bolt (4x)      Hex Nut (4x)      Hole Plug

## What's what?

Important components labeled

**9-V Battery**  
Must be installed before use.

**Reset Button**  
For performing reset procedures on keypad

**Connection Terminals**  
For wiring to compatible AC/DC power source and gate operator or door opener

**Relay Status LED**  
Indicates whether relay is active or inactive (Relay active when lit)

**Power LED**  
Indicates whether or not unit has power

**Programming Button**  
For pairing transceiver to keypad or resetting transceiver

**Programming LED**  
Indicates status of pairing process

**Keypad Unit**  
Back of front panel shown. Internal wiring not shown for clarity.

**Transceiver**  
Shown with cover removed. Internal wiring not shown for clarity.

**3** Unlock and remove front panel of keypad unit; then using included carriage bolts and hex nuts, attach unit to pedestal as shown.

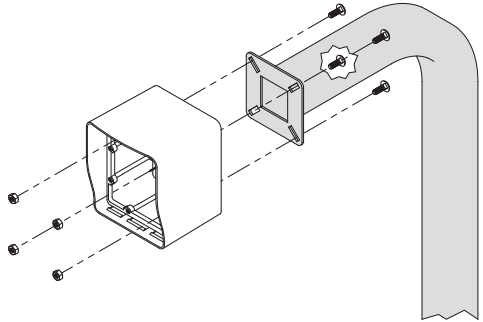

**4** Using Tek screws, zip ties, or other means of securing, attach transceiver to inside wall or other surface inside gate operator.

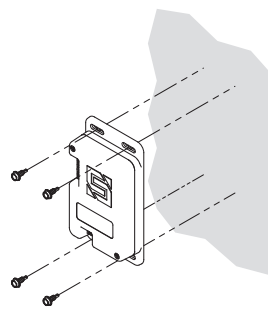

**CAUTION!**  
The transceiver is not weatherproof and must be mounted inside a weatherproof enclosure. Internal components can be damaged if exposed to the elements.  
**Failure to comply will VOID WARRANTY.**

**WARNING!**  
**AUTOMATIC GATES CAN CAUSE SERIOUS INJURY OR DEATH!**  
**ALWAYS CHECK** that the **GATE PATH IS CLEAR BEFORE OPERATING!**  
**REVERSING** or other **SAFETY DEVICES SHOULD ALWAYS BE USED!**

## 5a Connect transceiver

Gate Operator Timer-to-Close  
**OFF**

### Ridge Transceiver      Gate Operator / Door Opener

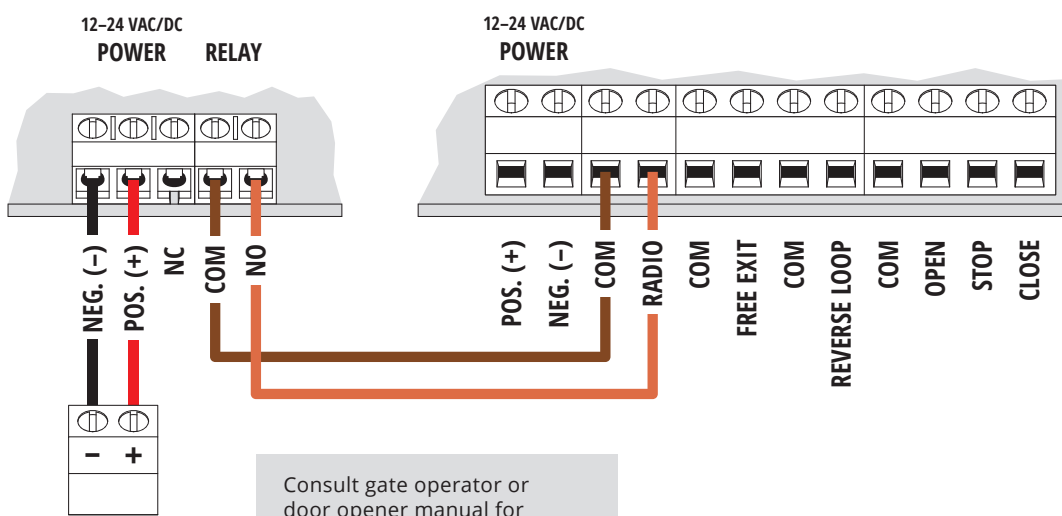

12-24-VAC/DC Power Source (Not Included)

Consult gate operator or door opener manual for exact connections.  
Terminals vary widely across manufacturers and models.

## 5b Connect transceiver

Gate Operator Timer-to-Close  
**ON**

### Ridge Transceiver      Gate Operator / Door Opener

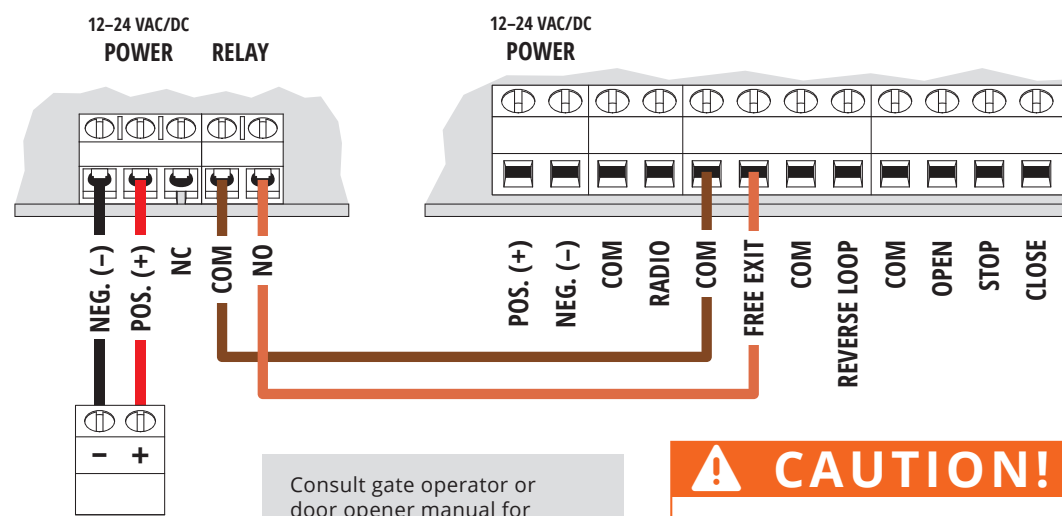

12-24-VAC/DC Power Source (Not Included)

Consult gate operator or door opener manual for exact connections.  
Terminals vary widely across manufacturers and models.

**CAUTION!**  
A closing gate can cause injury to persons or damage to property.  
**ALWAYS USE SAFETY DEVICES!**

OR

**6a** Remove transceiver cover; then hold down Programming Button on circuit board for 3 seconds and let go.

LED will light and stay on

**6b** Pair keypad unit with transceiver by entering sequence below on keypad.  
(Make sure 9-V battery is connected on keypad unit)

1 2 5 1 → 9 → \_ \*

Master Code (1251 is default)      Channel (1 for A, 2 for B)

**NOTE:** Green arrow indicates "good" tone on keypad unit.

**6c** While pairing, keypad unit will beep and flash. Once transceiver LED goes off and "good" tone is heard on keypad unit, pairing is complete.

LED will go off

**7** Add Access Code(s) to Channel A.  
(To add multiple codes, enter each of them before pressing pound key)

1 2 5 1 → 1 → \_ \_ \_ \_ → #

Master Code (1251 is default)      Sub Mode      Access Code(s) (4 digits; numbers only)

**NOTE:** The Master Code is for programming only and will not trigger the relay.

**8** Make sure gate path is clear; then enter access code on keypad and confirm gate opens.  
(If keypad locks up, repeat Step 6)

**INSTALLATION COMPLETE!**

Your system is ready to use.

## A1 Additional programming

**Delete Code(s)**  
(To delete multiple codes, enter each of them before pressing pound key)

1 2 5 1 → 2 → \_ \_ \_ \_ → #

Master Code (1251 is default)      Sub Mode      Code(s) to Be Deleted (4 digits; numbers only)

**Set Unique Keypad ID**  
(This feature is for added security and allows multiple keypad units and transceivers to be used. If Keypad ID is changed, keypad unit and transceiver must be paired again.)

1 2 5 1 → 9 → 5 → \_ \_ \_ \_ → #

Master Code (1251 is default)      Sub Mode      Unique Keypad ID (4 digits; numbers only)

**NOTE:** Green arrow indicates "good" tone on keypad unit. Always wait for good tone before moving on.

## A2 Additional programming (continued)

### Change Master Code

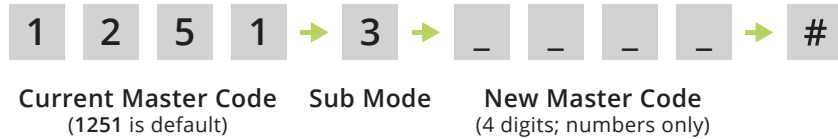

### Add Latch Code



### Add One-Time-Use Code (Channel A ONLY)



### Add Access Code(s) to Channel B

(To add multiple codes, enter each of them before pressing pound key)

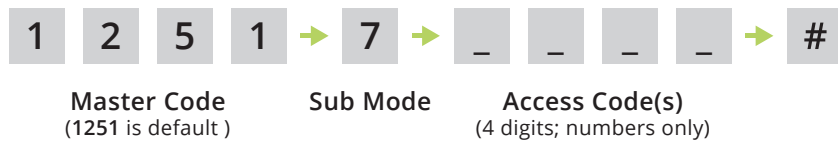

### Delete All Codes (Cannot Be Undone)



### Set Relay Output Time



### Configure Three Strikes, You're Out

(This feature is designed to deter unauthorized users who enter an incorrect code three times in a row. When this happens, the keypad unit will sound an alarm for 30 seconds, and then it will go into a period of lockdown for a full 90 seconds.)

#### Check Status

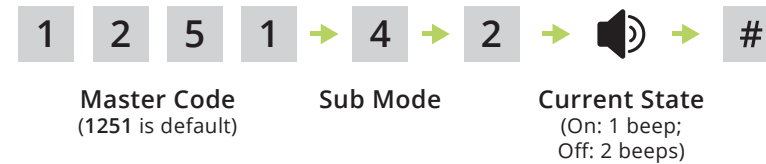

#### Toggle On or Off

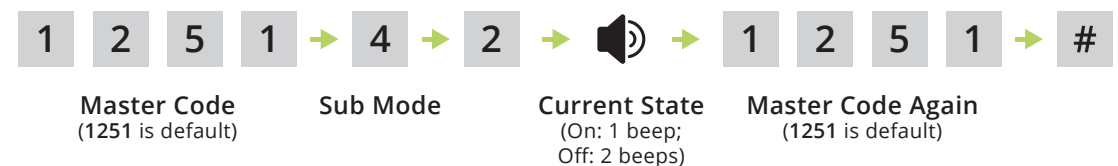

NOTE: Green arrow indicates "good" tone on keypad unit. Always wait for good tone before moving on.



## Programming Sub Modes

- |  |  |
|--|--|
| <b>1</b> Add Access Code(s) to Channel A       | <b>8</b> Add One-Time-Use Code (Channel A) |
| <b>2</b> Delete Code(s)                        | <b>9</b> Pairing and Setting Keypad ID     |
| <b>3</b> Change Master Code                    | <b>0</b> Delete All Codes                  |
| <b>4</b> Configure "Three Strikes, You're Out" |  |
| <b>5</b> Add Latch Code                        |  |
| <b>6</b> Set Relay Output Time                 |  |
| <b>7</b> Add Access Code(s) to Channel B       |  |

## Things to Know

### The Star Key (\*)

The star key deletes your current entry. If you happen to make a mistake keying in a code, simply press the star key to delete the entire entry and start over.

### The Pound Key (#)

The pound key is good for one thing and one thing only: exiting Programming Mode. Whenever you're in Programming Mode, simply press the pound key to get out.

### Reset Procedures

If for some reason the Master Code is forgotten or the unit needs to be reset to factory defaults, two reset procedures are available: **Master Reset** and **Unit Reset**.

These procedures can be found in **Section B1**.

## B1 Reset Procedures (Keypad Unit)

**NOTE: If an error is made during these procedures, an "error" tone will sound and you must start again from the beginning.**

**NOTE: Unit must have power.**

### Master Reset

(Used if the Master Code is unknown, if the Latch Code is unknown and the unit is in Latch Mode, or if the Sleep Code is unknown and the unit is in Sleep Mode. All other codes will be retained after completing this procedure.)

**Step 1 - Remove front panel of keypad unit.**

**Step 2 - Disconnect battery.**

**Step 3 - Press and hold Reset Button; reconnect battery; then release Reset Button.** Unit will sound one (1) tone. Release Reset Button after you hear tone.

**Step 4 - Press Star key (\*) on keypad three (3) times and wait up to 30 seconds.**

**Step 5 - Reattach front panel onto keypad unit.**

The Master Code is now reset to default (**1251**).

### Unit Reset

(Used to reset unit to factory default settings. The Master Code will be retained.)

**IMPORTANT: FOLLOWING THIS PROCEDURE WILL DELETE ALL CODES BUT MASTER CODE!**

**Step 1 - Remove front panel of keypad unit.**

**Step 2 - Disconnect battery.**

**Step 3 - Press and hold Reset Button; reconnect battery; then release Reset Button.** Unit will sound one (1) tone. Release Reset Button after you hear tone.

**Step 4 - Enter Pound (#) Star (\*) Pound (#) on keypad.** (Unit will sound "good" tone.)

**Step 5 - Enter Master Code (1251 is default) on keypad.** (Unit will beep continuously.)

**Step 6 - While unit is beeping, disconnect and reconnect battery.** Unit will then go through power-up procedure.

**Step 7 - Reattach front panel onto keypad unit.**

The unit is now reset to factory default settings. Follow **Master Reset** to reset Master Code.

**B2 Reset Procedure (Transceiver)**

**IMPORTANT: FOLLOWING THIS PROCEDURE WILL UNPAIR ALL DEVICES (KEYPADS, RTES, AND REMOTES) FROM THIS UNIT!**

**NOTE: Unit must have power.**

This procedure is used when there is interference from other devices such as on a circle drive or when two or more neighbors have Ridge products.

**Step 1 - Remove screws and cover from transceiver.**

**Step 2 - Press and hold Programming Button.**

**Step 3 - After about 15 seconds, release Programming Button.**  
LED will flash multiple times, indicating reset is in progress. Once complete, LED will go out.

**Step 4 - Press Star key (\*) on keypad three (3) times and wait up to 30 seconds.**

**Step 5 - Replace cover and secure screws on transceiver.**

The transceiver is now reset to factory default settings.

**Notes**

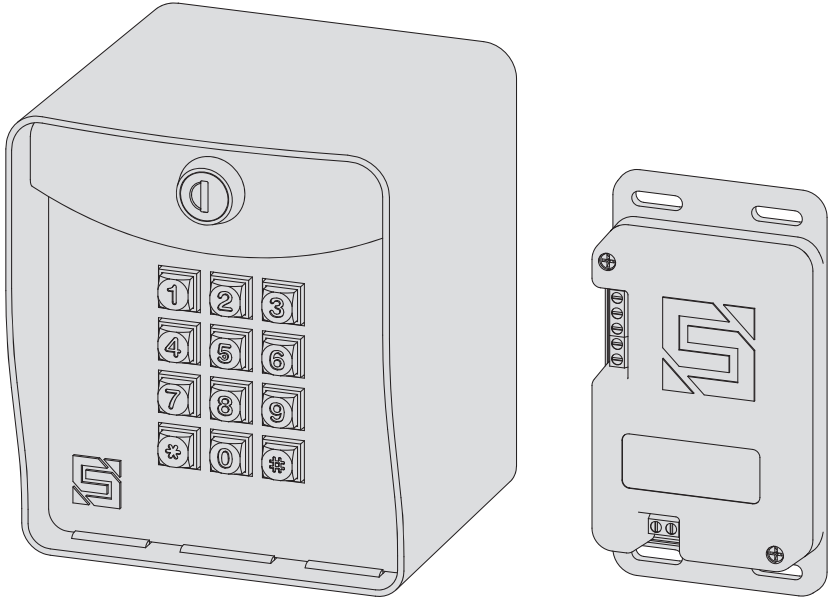

**Ridge  
14-500**

---

---

---

---

---

---

---

---