

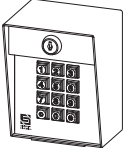





1 Carefully unpack box.

2 Make sure you have everything shown here.

 Keypad Unit

 Key



 Carriage Bolt
(4x)

 Hex Nut
(4x)

3 Unlock and remove front panel of keypad unit; then using carriage bolts and hex nuts, attach unit to pedestal as shown.

What's what?

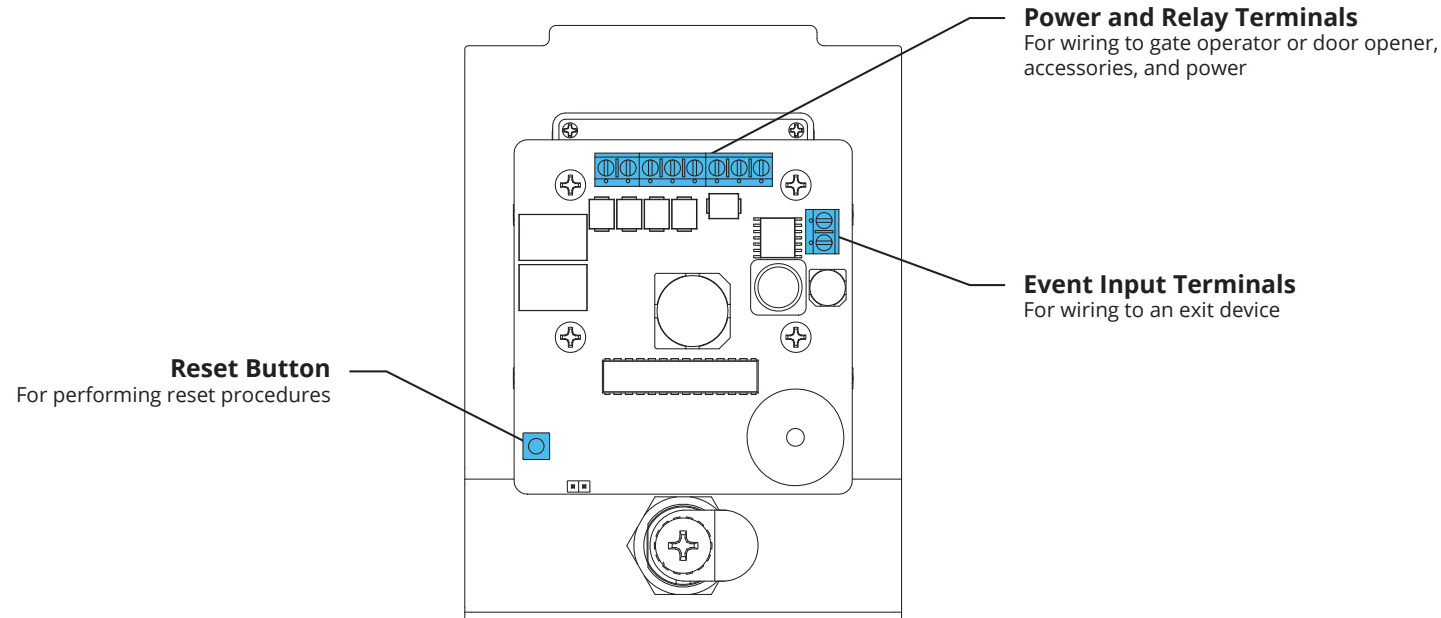
Important components labeled



Keypad Unit Front Panel

Shown as it would appear with front panel inserted into enclosure as in Step 4.

4 For ease of wiring, insert front panel into enclosure as shown.

! WARNING!

AUTOMATIC GATES CAN CAUSE SERIOUS INJURY OR DEATH!

ALWAYS CHECK that the GATE PATH IS CLEAR BEFORE OPERATING!

REVERSING or other SAFETY DEVICES SHOULD ALWAYS BE USED!

5a Make the connections
Wiring for Gate Operator or Door Opener

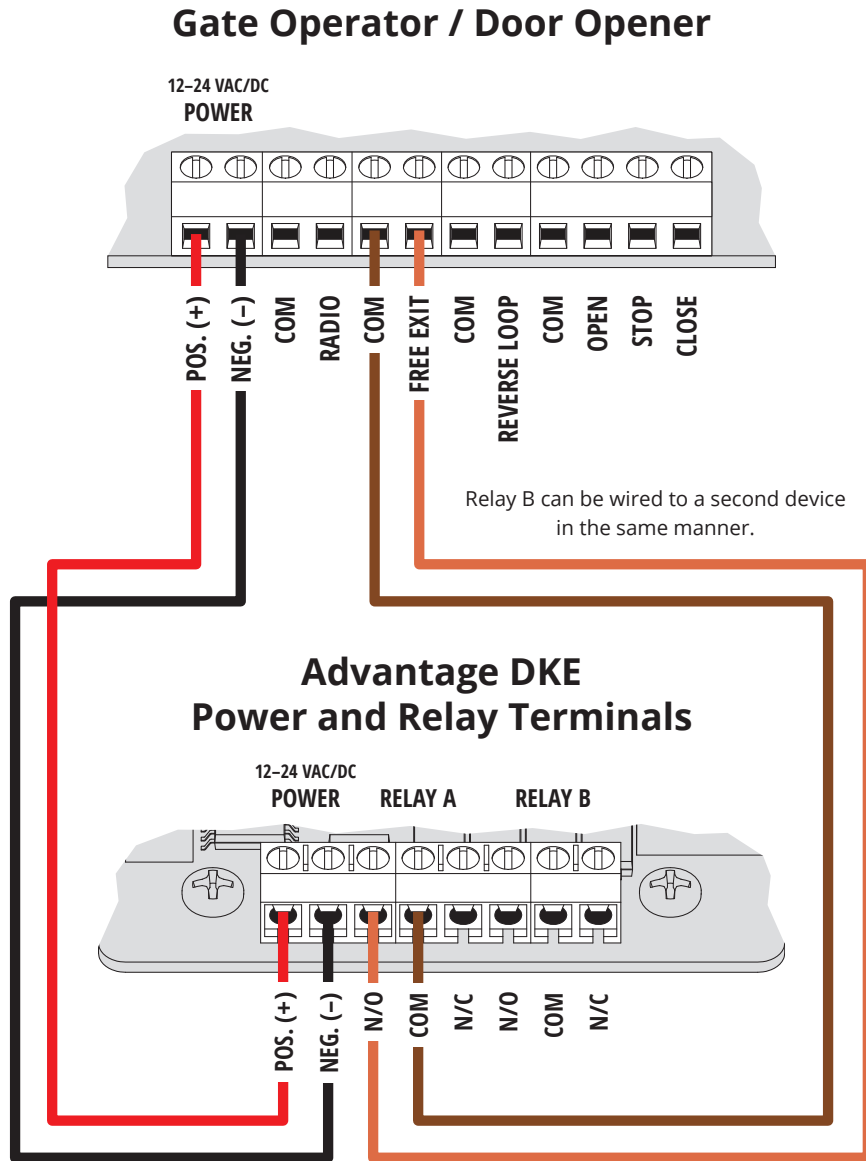

5b Make the connections
Wiring for Electric Door Strike and Exit Device

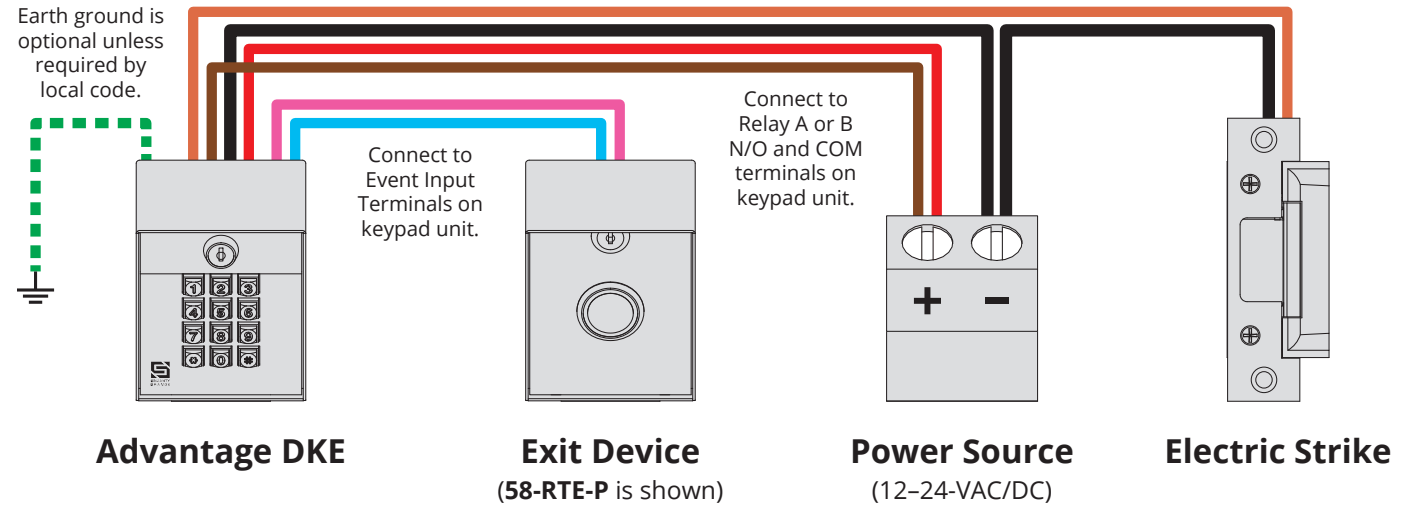

5c Make the connections
Wiring for Mag Lock and Exit Device

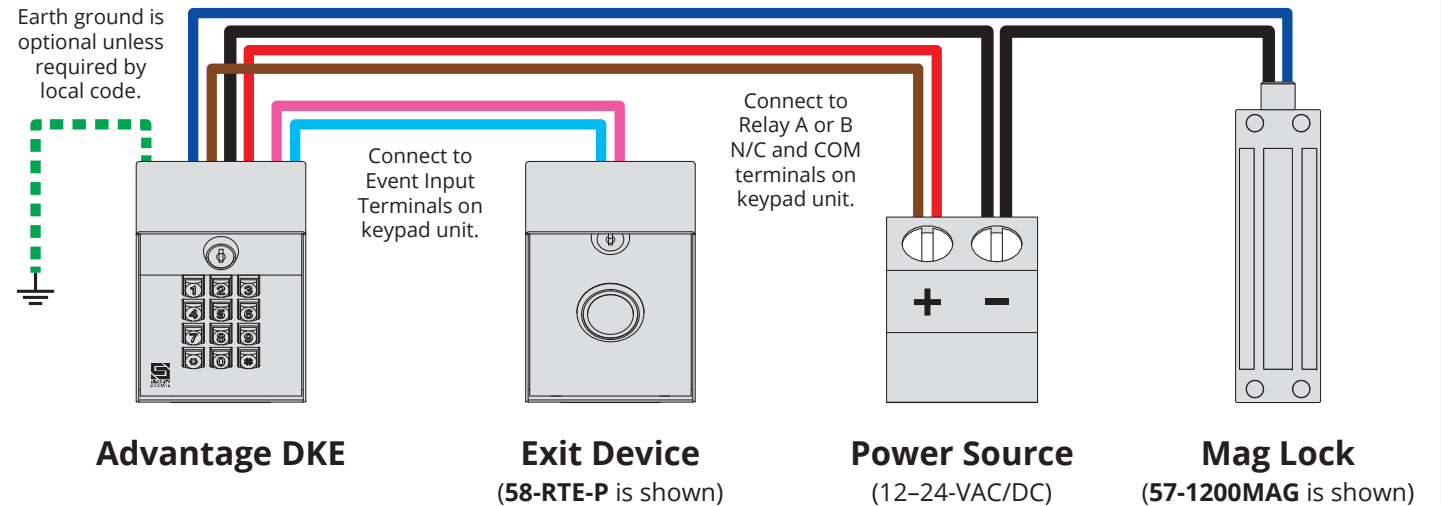





6 Add Access Code(s) to Relay A.
(To add multiple codes, enter each of them before pressing pound key)

1 2 5 1 → 1 → _ _ _ _ → #

Master Code (1251 is default) Sub Mode Access Code(s) (4 digits; numbers only)

NOTE: The Master Code is for programming only and will not trigger the relay. The green arrow indicates a "good" tone on the keypad. An incorrect entry will sound a "bad" tone.

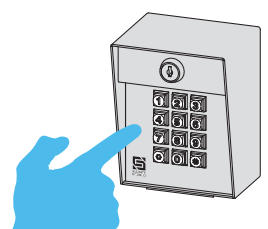
7 Make sure gate path is clear; then enter access code on keypad and confirm gate opens.

INSTALLATION COMPLETE!

Your system is ready to use.

A1 Additional Programming

Delete Code(s)
(To delete multiple codes, enter each of them before pressing pound key)

1 2 5 1 → 2 → _ _ _ _ → #

Master Code (1251 is default) Sub Mode Code(s) to Be Deleted (4 digits; numbers only)

Change Master Code

1 2 5 1 → 3 → _ _ _ _ → #

Current Master Code (1251 is default) Sub Mode New Master Code (4 digits; numbers only)

Set Latch Code

1 2 5 1 → 5 → _ _ _ _ → #

Master Code (1251 is default) Sub Mode Latch Code (4 digits; numbers only)

Things to Know

The Star Key (*)
The star key deletes your current entry. If you happen to make a mistake keying in a code, simply press the star key to delete the entire entry and start over.

The Pound Key (#)
The pound key is good for one thing and one thing only: exiting Programming Mode. Whenever you're in Programming Mode, simply press the pound key to get out.

Reset Procedures
If for some reason the Master Code is forgotten or the unit needs to be reset to factory defaults, two reset procedures are available: **Master Reset** and **Unit Reset**.

These procedures can be found on **Page 5** of this guide.

NOTE: Green arrow indicates "good" tone on keypad. Always wait for good tone before moving on.

Programming Sub Modes

- 1 Add Access Code(s) to Relay A
- 2 Delete Code(s)
- 3 Change Master Code
- 5 Set Latch Code (Relay A ONLY)
- 6 Set Relay Output Time
- 7 Add Access Code(s) to Relay B
- 9 Configure Event Input
- 0 Delete All Codes

A2 Additional Programming (continued)

Set Relay Output Time

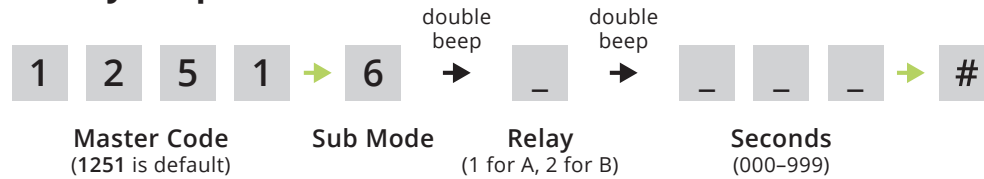

Add Access Code(s) to Relay B

(To add multiple codes, enter each of them before pressing pound key)

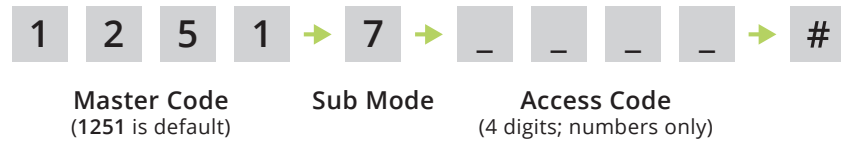

Delete All Codes (Cannot Be Undone)



Configure Event Input

(Allows an external device to affect keypad operation or trigger a relay)

Modes

Mode 1 - Remote Inactive Mode

Disables all Relay A codes when input is received from external device

Mode 2 - Arming Circuit Mode

Turns on keypad unit when input is received from external device

Mode 3 - Remote Open Mode

Triggers either Relay A or Relay B when input is received from external device

Mode 0 - Event Input Disabled

Set Mode 1, Mode 2, Disable, or Check Current Mode

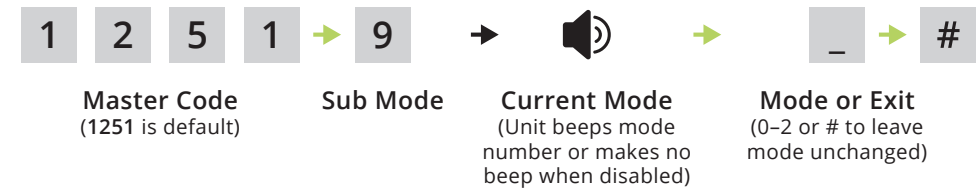

Set Mode 3

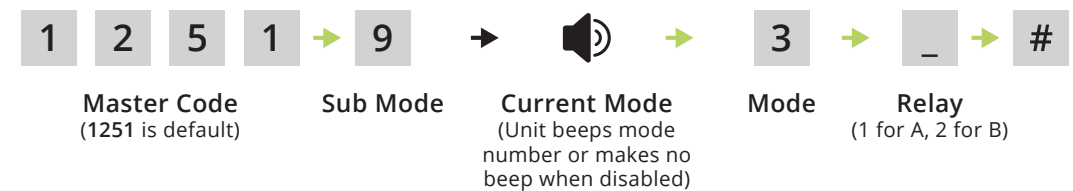

NOTE: Green arrow indicates "good" tone on keypad. Always wait for good tone before moving on.

