

Installation and Operation Manual



REQUEST TO EXIT - NO TOUCH
MULLION MOUNT

S-RTE-M



your *partner* in access control

Security Brands, Inc. Two-Year Limited Warranty

This warranty applies to all product or equipment specifically and solely designed for and manufactured by Security Brands, Inc. Any equipment used in Security Brands, Inc. products that is not manufactured by Security Brands, Inc. (this includes all products purchased by Security Brands, Inc. for OEM purposes) is liable and subject to warranty terms of that specific manufacturer. Those products used by Security Brands, Inc. which are not covered by the Security Brands, Inc. Two-Year Limited Warranty are: TekTone, HID, SecuraKey and Omniprint.

If your Security Brands, Inc. product is defective and returned within two years of the date of purchase, we will repair it, or at our option, replace it at no charge to you. If we repair your Security Brands, Inc. product, we may use new or reconditioned parts. If we choose to replace your Security Brands, Inc. product, we may replace it with a new or reconditioned unit of the same or similar design. The repair or replacement will be warranted for 90 days or the remainder of the original two-year warranty period, whichever is longer.

Limitations:

Implied warranties, including those of fitness for a particular purpose and merchant ability (an unwritten warranty that the product is fit for ordinary use), are limited to two years from date of purchase. We will not pay or recompense for loss of time, inconvenience, loss of use of your Security Brands, Inc. product, service calls or property damage caused by your Security Brands, Inc. product, its failure to work or any other incidental or consequential damages. Some states do not allow limitations on how long an implied warranty lasts or the exclusion or limitation of incidental or consequential damages, so the above exclusions or limitations may not apply to you.

What we ask you to do:

To get warranty service for your Security Brands, Inc. product, you must provide proof of the date of purchase. Contact the original dealer or installer of the product and return your Security Brands, Inc. product along with the receipt to them. If you have problems locating the dealer or installer, please contact Security Brands, Inc. at (303) 799-9757 and we will direct you to an authorized dealer or distributor of Security Brands, Inc. products. If you ship your Security Brands, Inc. product, you must prepay all shipping costs. We suggest that you retain your original packing material in the event you need to ship your Security Brands, Inc. product. On return, include your name, address, phone number, proof of date of purchase, RMA # (obtained through an authorized Security Brands, Inc. dealer or distributor) and a brief description of the operating problem. IF AN RMA # IS NOT LISTED ON THE EXTERIOR OF THE PACKAGING OR THE PAPERWORK YOU INCLUDE, THE PRODUCT WILL BE RETURNED TO YOU. NO SERVICE WORK WILL BE PERFORMED UNTIL AN RMA # IS OBTAINED AND INCLUDED WITH YOUR SHIPMENT TO US.

What this warranty does not cover:

This warranty does not cover defects resulting from accidents, damage while in transit, alterations, unauthorized repair, failure to follow instructions, misuse, fire, flood or acts of God. Nor do we warrant your Security Brands, Inc. product to be compatible with any particular external device or peripheral. If the warranty has expired on your Security Brands, Inc. product or if your product is NOT covered, please contact your dealer or installer for advice on whether we will repair your Security Brands, Inc. product and other repair information, including estimated repair costs and other charges.

This warranty is the only one we give on our products, and it sets forth all of our responsibilities regarding your Security Brands, Inc. product. There are no other express warranties.

State Law Rights:

This warranty gives you specific legal rights and you may also have other rights that vary from state to state.

Serial # _____



**TECHNICAL SUPPORT
303-799-9757 OR
TECHSUPPORT@SECURITYBRANDSINC.COM**

Wiring Diagram:

Wiring for Request To Exit No Touch Sensor

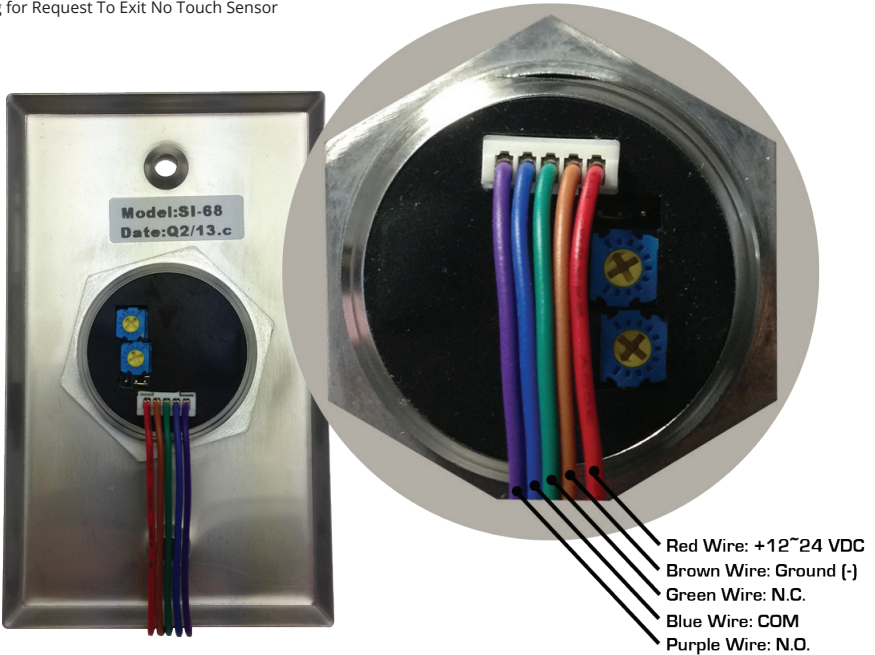

Specifications:

Power Input	12-24 VDC	±10%
Range	1.25"-4.5" (± 25%)	
Output Loading	1 A @ 30 VDC (Max.)	
Output State	Trigger state (0.5-20 seconds) or toggle mode output	
Lifetime	Infrared Sensor: 100,000 hours	Relay: 1,000,000 uses
Indicator	Standby: RED Proximity: GREEN	Color of indicator light is adjustable
Case	Stainless Steel	
Current Consumption	32 mA (relay triggered)	24 VDC
Dimensions	4.5" H x 1.5" W x 1.5" D	
Weight	.14 lbs.	

Features:

- Adjustable sensor range up to 4.5".
- Stainless-steel faceplate, powder-coated housing.
- Weather resistant for outdoor use.
- 1 A relay, adjustable trigger duration 0.5-20 seconds or toggle.
- LED illuminated sensor area for easy identification.
- Selectable LED colors (turns from red to green or green to red) to show sensor activated.

www.ShopAmericanAccess.com | (800) 878-7829 | Sales@ShopAmericanAccess.com

Sample Installations:

A. Controller Door Opening

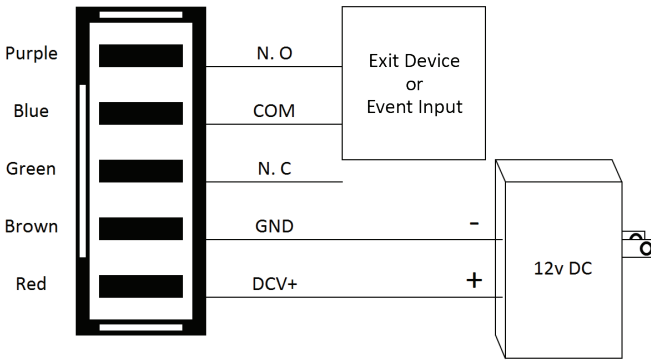

B. Connect Relay

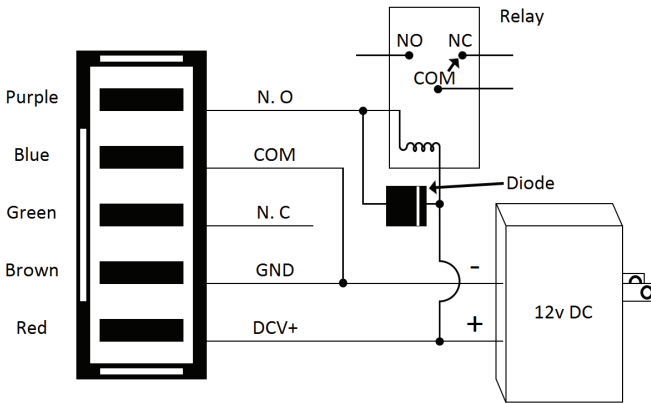

C. Electric Lock

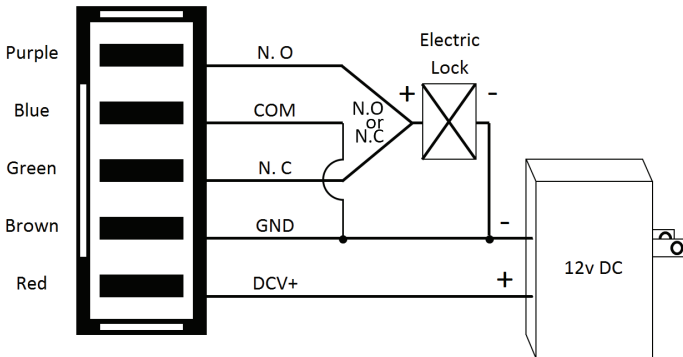

Installation:

1. Run 4 wires through the pedestal (or similar mounting hardware).
2. Connect the 4 wires to the Request-to-Exit Sensor according to the Wiring Diagram above.
3. Reattach the Stainless Faceplate to the enclosure taking care not to crimp the wires.
4. Remove clear protective film from the sensor before use.

WARNING: Do not connect any device that will exceed 1 A @ 30 VDC.

Adjusting the Sensor Range and Trigger Time:

1. The sensor range can be adjusted from 1.25" to 4.5".

2. The trigger time can be adjusted from 0.5 to 20 seconds or toggle.

NOTE: Do not force the adjustment trimpots to turn. Only minimal force is needed.

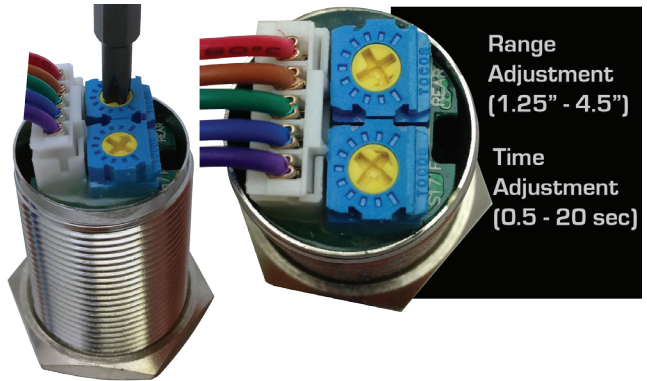

Care and Cleaning for the Sensor:

The sensor requires special care to ensure reliability and a long operating life.

1. Use a soft, clean cloth for cleaning. Use the mildest type of cleaner available.
2. When cleaning, spray the cleaning solution onto the cleaning cloth instead of the unit.
3. Be sure to wipe off any excess liquid from the sensor. Wet spots or areas may affect the sensor's performance.

WARNING: Incorrect mounting which leads to exposure to rain or moisture inside the enclosure could cause a dangerous electric shock, damage the device, and void the warranty.

CONTACT INFO

Customer Service

(800) 541-5677

customerservice@securitybrandsinc.com

Technical Support

(800) 541-5677

techsupport@securitybrandsinc.com

Both services are available free of charge between **8:00 a.m. and 4:30 p.m. Mountain Time**.
When you call, please have your **model and serial number** handy to help our technicians assist you.



SECURITY BRANDS INC™
your *partner* in access control



your *partner* in access control

www.ShopAmericanAccess.com | (800) 878-7829 | Sales@ShopAmericanAccess.com