

NOTES:

1. REMOVE ALL BURRS AND SHARP EDGES.

REVISION			
REV	DESCRIPTION	DATE	APPROVED
A	INITIAL RELEASE	8/29/2017	JW

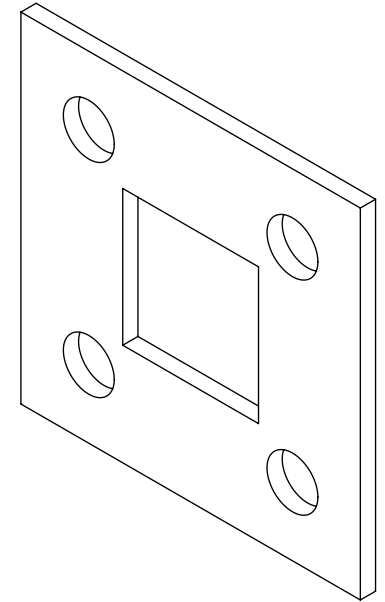
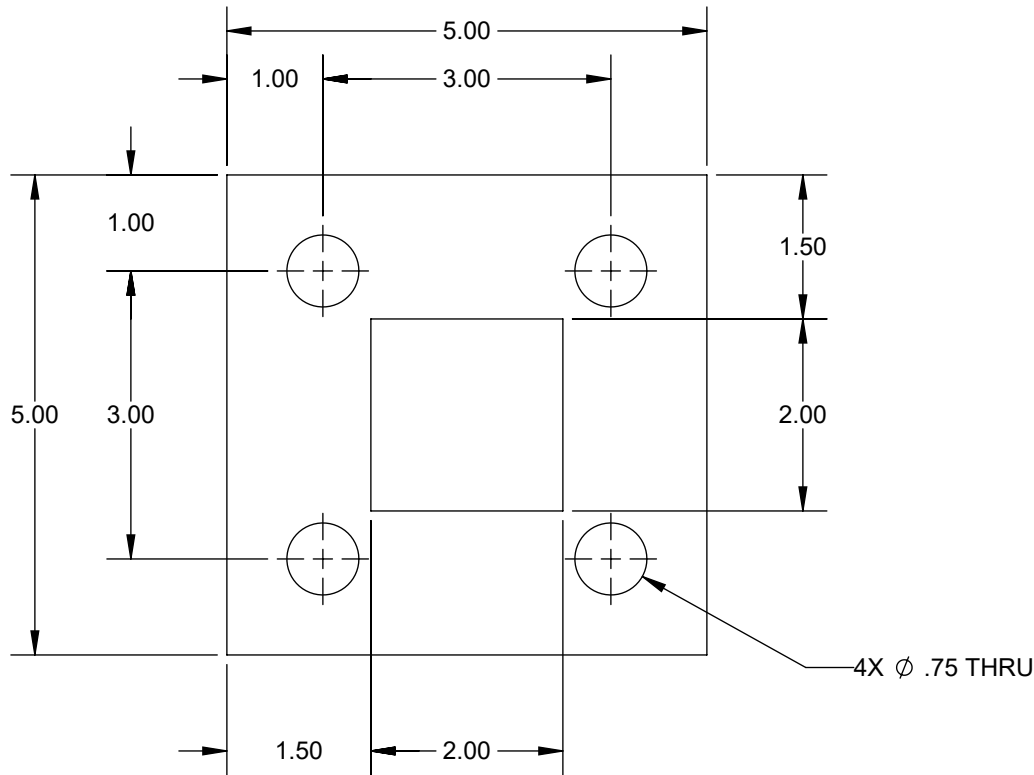

UNLESS OTHERWISE SPECIFIED:		NAME	DATE
DIMENSIONS ARE IN INCHES TOLERANCES: FRACTIONAL ±1/16 ANGULAR: MACH ±1° BEND ±3° .XX ±.03 .XXX ±.010	DRAWN	JW	8/29/2017
	CHECKED	CB	8/29/2017
	ENGINEERING	JW	8/29/2017
	Q.A.	-	
DIMENSIONS AND TOLERANCES PER ASME Y14.5M-2004	PROPRIETARY AND CONFIDENTIAL		
MATERIAL MILD STEEL, 6 MM	THE INFORMATION CONTAINED IN THIS DRAWING IS THE SOLE PROPERTY OF SECURITY BRANDS, INC. AND/OR ITS SUBSIDIARIES. REPRODUCTION IN PART OR IN WHOLE WITHOUT THE WRITTEN PERMISSION OF SECURITY BRANDS, INC. IS PROHIBITED.		
FINISH PRE-GALVANIZED			
DO NOT SCALE DRAWING			



TITLE
BASE PLATE - PEDESTAL

SIZE A	DWG. NO. -	REV A
------------------	---------------	-----------------

SCALE: 1:2 SHEET 1 OF 1